

An economical and versatile alternative to a sit-down forklift.

CAPACITY

- 2,200 lb at 24" load center

LIFT HEIGHTS

- 118 inches
- 130 inches

OPERATION/CONTROLS

- Thumb throttle, lift, lower, rapid lower, horn and reversing switch are easily located on the ergonomically correct top mount handle
- On/Off key switch, emergency power cutoff switch and hour meter/battery discharge indicator mounted on dash
- Clear view mast with exterior lift cylinders for excellent forward visibility
- Automatic neutral braking on throttle release
- Braking activation at top and bottom of handle working range

DRIVE SYSTEM

- High performance vertically mounted Curtis SepEx™ separately excited motor provides maximum torque throughout entire travel speed
- Precision helical drive gears provide quiet operation and transfers power more efficiently from drive motor to axle
- Long life electromagnetic braking system

HYDRAULIC SYSTEM

- Lifting rams are hard chromed plated for long life and mounted outboard of lifting mast for even load lifting
- Pump unit, motor and solenoid actuated, pressure mounted outboard of lifting mast for even load lifting

ELECTRICAL SYSTEM

- 24 volt
- State-of-the-art programmable Curtis transistor motor controller provides smooth and seamless travel
- Auto reset circuit breaker and fused control circuit designed to protect the electrical system

FORKS/CHASSIS

- 42" long forged forks, 23"OD adjustment on ITA class II carriage
- Dual cylinder 3 forward & 6 backward mast tilt
- Channel mast fitted with heavy-duty roller bearings and dual lift chains
- 32" high load backrest



Tilt Mast

Dash Mounted Controls

Easy Battery Access

WHEELS

- Low effort steering with center drive tire and stabilizer wheels
- 9.8" x 3.0" rubber drive wheel
- 6.3" x 3.2" polyurethane load wheels
- 4.0" x 2.3" polyurethane stabilizer wheels

OPTIONAL EQUIPMENT

- Consult factory

Specifications

Designation	MODEL		XPC-22		
	Type	-	powered lift stacker		
	Capacity	lbs.	2200		
	Power	-	battery		
	Maximum Lifting Height	in.	118	130	
Performance	Load Center	in.	24		
	Maximum Travel Speed - Loaded	A	mph	1.9	
	Maximum Travel Speed - Unloaded		mph	3.1	
	Maximum Lifting Speed - Loaded		in./sec	6.9	
	Maximum Lowering Speeds - Loaded		in./sec	12 / 4.9	
	Minimum Turning Radius		in.	52	
	Minimum Aisle Width		in.	99	
	Gradeability	Laden	%	5	
	Gradeability	Unladen	%	7	
	Voltage / Amp Hour		V/AH	24 / 270	
	Downrated Capacity at Maximum Lift		lbs.	2200	1750
	Motor	Travel		HP	1.25
Lift			HP	4.0	
Chassis	Mast Extended Height with Backrest	B	in.	152	162
	Mast Lowered Height	C	in.	86	86
	Mast Stages (3° forward - 6° backward)		#	2	
	Overall body Length	D	in.	56	
	Overall Length with Forks		in.	99	
	Overall Rear Height	E	in.	61	
	Rear Body Width		in.	34	
	Rear Body Height	F	in.	35	
	Handle Width		in.	17	
	Fork Length	G	in.	42	
	Fork Width		in.	4	
	Lowered Fork Height		in.	1	
	Minimum Ground Clearance		in.	2	
	Battery Compartment (LxWxH)		in.	9.75 x 32 x 21.75	
Wheels	Wheel Type Drive / Load		in.	polyurethane	
	Wheel Base	H	in.	46	
	Drive Wheel		in.	9.8 x 3.0	
	Load Wheels (width)		in.	6.3 x 3.2	
	Stabalizers (width)		in.	4.0 x 2.3	
Weight	Service Weight Without Battery	lbs.	3650	3750	
	Minimum Battery Weight	lbs.	525		

Performance may vary due to motor and system efficiency tolerances and represents nominal values under typical operating conditions.

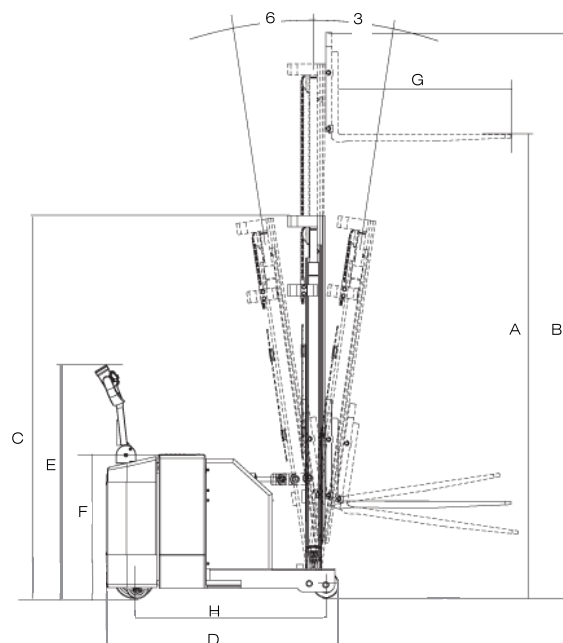

Be A Safe Operator.

- Do not operate this truck unless you have been trained and authorized to do so.
- Do not operate this truck until you have checked its condition. Give special attention to tires, battery, controls, lifting systems (including switches), brakes, steering mechanism, guards and safety devices.
- Report the need for truck repairs to your supervisor promptly. Do not operate the truck. Neglect may cause a minor repair to become a major service problem or cause the truck to become unsafe.
- The powered lift stacker is intended for use on level surfaces only.
- Do not exceed the rated capacity of the vehicle as marked on the name plate. Do not lift with the fork tips or one fork only, and be sure load is centered and the 24" (610mm) load center is not exceeded.
- Do not handle unstable or loosely stacked loads. Use special care when handling long, high or wide loads, to avoid tipping, loss of load, or striking bystanders.
- Always look in direction of travel. Keep a clear view and when load obstructs visibility, travel with load trailing (except when climbing ramps).
- Watch swing clearance when turning near walls, racks, pillars or other obstacles.
- Start, stop, change direction, travel and brake smoothly. Slow down for turns and on uneven or slippery surfaces that could cause truck to slide or tip. Be aware that the truck behaves differently without a load than with a load.
- Observe applicable traffic regulations and yield right of way to pedestrians. Slow down and sound horn at all aisle intersections and where vision is obstructed. Do not ride on truck unless equipped with a rider platform.
- Do not carry passengers.



85 Heart Lake Road South
Brampton, Ontario, Canada L6W 3K2
Phone: 905-457-3900 • Fax: 905-457-2313
www.BlueGiant.com

AUTHORIZED DISTRIBUTOR

BLUE GIANT EQUIPMENT CORPORATION

BLUE GIANT offers a full line of Loading Dock Equipment including Dock Levelers, Vehicle Restraints, Dock Seals and Shelters and Material Handling Solutions. Concurrent with our continuing product improvement program, specifications are subject to change without notice. Please contact BLUE GIANT for latest information. Some features illustrated may be optional in certain market areas.