

Quality, durability and efficient pallet management for medium duty applications.

CAPACITY

- 4,500 lb

OPERATION/CONTROLS

- Thumb throttle, lift, lower, horn and reversing switch are easily located on the ergonomically correct bottom mount handle
- On/Off key switch, power disconnect and hour meter/battery discharge indicator mounted on dash
- Braking activation at top and bottom of handle working range
- Automatic neutral braking on throttle release
- Low effort steering

DRIVE SYSTEM

- High performance vertically mounted Curtis SepEx™ separately excited motor provides maximum torque throughout entire travel speed
- Precision helical drive gears provide quiet operation and transfer power more efficiently from drive motor to axle
- No directional contactors therefore less maintenance. Single line contactor operates with an integrated power disconnect switch
- Easy access cover exposes electrical and major mechanical components for inspection and maintenance
- Long life drum brake system mounted on motor armature shaft intensifying the braking power through the double reduction transmission

HYDRAULIC SYSTEM

- Lifting rams are hard chromed plated for long life and mounted for even load lifting
- Pump unit, motor and solenoid actuated, pressure compensated lowering valve are easily accessible

FORKS/CHASSIS

- 48" long forks, 27" fork width O.D.

ELECTRICAL SYSTEM

- 24 volt system
- State-of-the-art programmable Curtis transistor controller motor provides smooth and seamless control
- Auto reset circuit breaker and fused control circuit designed to protect the electrical system



Shown with optional accessories



Easy Access Controls

Easy Battery Access

WHEELS

- Tapered roller bearings (drive wheel) operating in oil sealed case
- Greasable sealed (load wheels) ball bearings
- Two extra heavy-duty (transmission), tapered roller bearings
- Self-lubricating (fork linkage), heat treated roller bearings

OPTIONAL EQUIPMENT

- 48" high load backrest
- Battery pack with built-in charger
- Maintenance-free and industrial batteries

Specifications

Designation	MODEL		XPT45/27x48
	Type	--	low lift walkie
	Capacity	lbs.	4500
	Power	-	battery
Performance	Load Center	in.	24
	Maximum Travel Speed - Loaded	mph	2.9
	Maximum Travel Speed - Unloaded	mph	3.7
	Maximum Lifting Speed - Loaded	in./sec	2
	Maximum Lowering Speed - Loaded	in./sec	2
	Minimum Turning Radius	in.	65.6
	Minimum Aisle Width	in.	79
	Gradeability (Laden / Unladen)	%	5 / 7
	Control	-	transistor, stepless
	Brake	-	electromagnetic
	Voltage / Amp Hour	V/AH	24 / 210
Motor	Drive	HP	1.25
	Lift	HP	3
Chassis	Lowered Fork Height	in.	3.3
	Raised Fork Height	in.	8
	Body Height	in.	32.3
	Overall Body Length	in.	73
	Overall Body Width	in.	30
	Handle Width	in.	17
	Fork Length	in.	48
	Fork Width O.D.	in.	27
	Individual Fork Width	in.	7.3
	Fork Thickness	in.	2.3
	Battery Compartment Size (L*W*H)	in.	28.25 x 9 x 24
	Minimum Ground Clearance	in.	1
	Wheels	Wheel Type Drive / Load	in.
Wheel Base		in.	59.21 / 56.89
Drive Wheel Dia. x W / Qty		in.	10.5 x 5 / x1
Load Wheel Dia. x W / Qty		in.	3.2 x 4.8 / x2 single
Stabilizer Dia. x W / Qty		in.	3.9 x 1.6 / x2
Weight	Service Weight Without Battery (nominal)	lbs.	860

Performance may vary due to motor and system efficiency tolerances and represents nominal values under typical operating conditions.



85 Heart Lake Road South
Brampton, Ontario, Canada L6W 3K2
Phone: 905-457-3900 • Fax: 905-457-2313
www.BlueGiant.com

BLUE GIANT EQUIPMENT CORPORATION

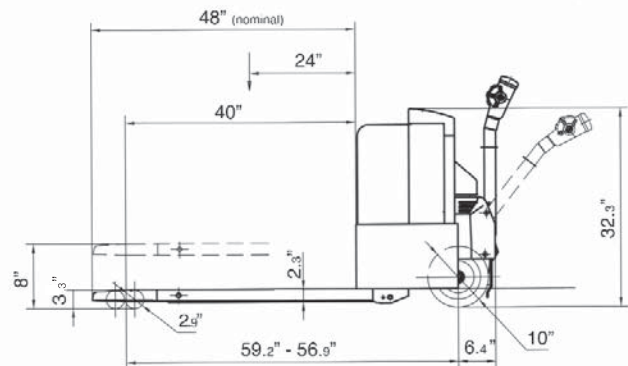
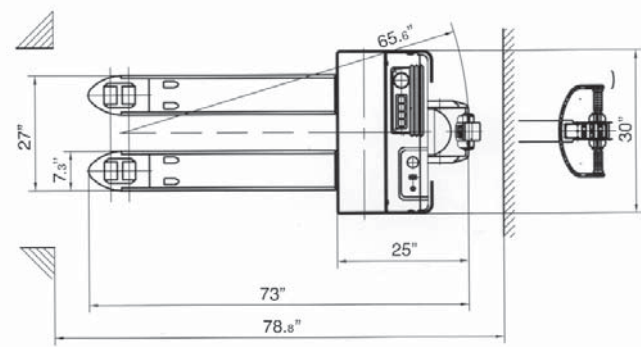

Illustration shown with tandem load wheels. Consult for availability.

Be A Safe Operator.

- Do not operate this truck unless you have been trained and authorized to do so.
- Do not operate this truck until you have checked its condition. Give special attention to tires, battery, controls, lifting systems (including switches), brakes, steering mechanism, guards and safety devices.
- Report the need for truck repairs to your supervisor promptly. Do not operate the truck. Neglect may cause a minor repair to become a major service problem or cause the truck to become unsafe.
- The electric pallet truck is intended for general use with minimal incline.
- Do not exceed the rated capacity of the vehicle as marked on the nameplate. Do not lift with the fork tips or one fork only, and be sure load is centered and the 24" (610mm) load center is not exceeded.
- Do not handle unstable or loosely stacked loads. Use special care when handling long, high or wide loads, to avoid tipping, loss of load, or striking bystanders.
- Always look in direction of travel. Keep a clear view and when load obstructs visibility, travel with load trailing (except when climbing ramps).
- Watch swing clearance when turning near walls, racks, pillars or other obstacles.
- Start, stop, change direction, travel and brake smoothly. Slow down for turns and on uneven or slippery surfaces that could cause truck to slide or tip. Be aware that the truck behaves differently without a load than with a load.
- Observe applicable traffic regulations and yield right of way to pedestrians. Slow down and sound horn at all aisle intersections and where vision is obstructed. Do not ride on truck unless equipped with a rider platform.
- Do not carry passengers.

AUTHORIZED DISTRIBUTOR

BLUE GIANT offers a full line of Dock Levelers, Dock Safety Equipment, Accessories, Ergonomic and Scissor Lift Equipment and Industrial Trucks. Concurrent with our continuing product improvement program, specifications are subject to change without notice. Please contact BLUE GIANT for latest information. Some features illustrated may be optional in certain market areas.